

TYPICAL ELEVATION

**MAXIMUM DESIGN LOAD RATING = + 55.0 PSF**  
 (FOR MAX. SIZE SHOWN ABOVE OR SMALLER) - 55.0 PSF  
 AS PERMITTED BY FBC REQUIREMENTS

NOTE:  
 APPLICABLE EGRESS REQUIREMENTS TO BE REVIEWED BY AHJ.

NOTE:  
 GLASS CAPACITIES ON THIS SHEET ARE  
 BASED ON ASTM E1300-09 (3 SEC. GUSTS)  
 AND FLORIDA BUILDING COMMISSION  
 DECLARATORY STATEMENT DCA05-DEC-219

THESE DOORS ARE RATED FOR LARGE & SMALL MISSILE IMPACT.  
 SHUTTERS ARE NOT REQUIRED.

**INSWING GLASS WOOD PIVOT DOOR**

DOORS WITH SILL APPROVED FOR INSTALLATION WHERE WATER INFILTRATION RESISTANCE IS REQUIRED.  
 DOORS WITHOUT SILL NOT APPROVED FOR WATER INFILTRATION RESISTANCE.

THIS PRODUCT HAS BEEN DESIGNED AND TESTED TO COMPLY WITH THE REQUIREMENTS OF THE 2017 (6TH EDITION) FLORIDA BUILDING CODE INCLUDING HIGH VELOCITY HURRICANE ZONE (HVHZ).

1BY OR 2BY WOOD BUCKS & BUCK FASTENERS BY OTHERS, MUST BE DESIGNED AND INSTALLED ADEQUATELY TO TRANSFER APPLIED PRODUCT LOADS TO THE BUILDING STRUCTURE.

ANCHORS SHALL BE CORROSION RESISTANT, SPACED AS SHOWN ON DETAILS AND INSTALLED PER MANUF'S INSTRUCTIONS. SPECIFIED EMBEDMENT TO BASE MATERIAL SHALL BE BEYOND WALL DRESSING OR STUCCO.

A LOAD DURATION INCREASE IS USED IN DESIGN OF ANCHORS INTO WOOD ONLY.  
 ALL SHIMS TO BE HIGH IMPACT, NON-METALLIC AND NON-COMPRESSIBLE.

MATERIALS INCLUDING BUT NOT LIMITED TO STEEL/METAL SCREWS, THAT COME INTO CONTACT WITH OTHER DISSIMILAR MATERIALS SHALL MEET THE REQUIREMENTS OF THE 2017 FLORIDA BLDG. CODE & ADOPTED STANDARDS.

THIS PRODUCT APPROVAL IS GENERIC AND DOES NOT PROVIDE INFORMATION FOR A SITE SPECIFIC PROJECT, i.e. LIFE SAFETY OF THIS PRODUCT, ADEQUACY OF STRUCTURE RECEIVING THIS PRODUCT AND SEALING AROUND OPENING FOR WATER INFILTRATION RESISTANCE ETC.  
 CONDITIONS NOT SHOWN IN THIS DRAWING ARE TO BE ANALYZED SEPARATELY, AND TO BE REVIEWED BY BUILDING OFFICIAL.

MANUFACTURER'S LABEL SHALL BE LOCATED ON A READILY VISIBLE LOCATION IN ACCORDANCE WITH SECTION 1709.9.3 OF FLORIDA BUILDING CODE.  
 LABELING TO COMPLY WITH SECTION 1709.9.2.

SEALED: 6/21/19  
 FL #29879

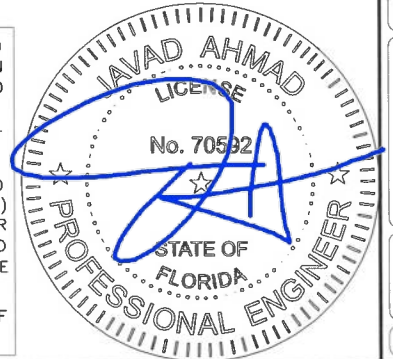

A- CONTRACTOR TO BE RESPONSIBLE FOR THE SELECTION, PURCHASE AND INSTALLATION OF THIS PRODUCT BASED ON THIS PRODUCT EVALUATION PROVIDED HE/SHE DOES NOT DEVIATE FROM THE CONDITIONS DETAILED ON THIS DOCUMENT.  
 B- THIS PRODUCT EVALUATION DOCUMENT WILL BE CONSIDERED INVALID IF ALTERED BY ANY MEANS.  
 C- SITE SPECIFIC PROJECTS SHALL BE PREPARED BY A FLORIDA REGISTERED ENGINEER OR ARCHITECT WHICH WILL BECOME THE ENGINEER OF RECORD (E.O.R.) FOR THE PROJECT AND WHO WILL BE RESPONSIBLE FOR THE PROPER USE OF THE P.E.D. ENGINEER OF RECORD, ACTING AS A DELEGATED ENGINEER TO THE P.E.D. ENGINEER SHALL SUBMIT TO THIS LATTER THE SITE SPECIFIC DRAWINGS FOR REVIEW.  
 D- THIS P.E.D. SHALL BEAR THE DATE AND ORIGINAL SEAL AND SIGNATURE OF THE PROFESSIONAL ENGINEER OF RECORD THAT PREPARED IT.

**af c**  
**AL-FAROOQ CORPORATION**  
 ENGINEERS & PRODUCT DEVELOPMENT  
 9360 SUNSET DRIVE, SUITE 220  
 MIAMI, FLORIDA 33173 (C.A.N. 3538)  
 TEL. (305) 264-8100 FAX. (305) 262-6978  
 COMP-ANL 19-54F-EWD

INSWING GLASS WOOD PIVOT DOOR (L.M.I.)  
**Exclusive Wood Doors, Inc.**  
 2000 N.W. 95Th Ave.  
 Doral, FL. 33172  
 Tel. (305) 477-2278 Fax. (305) 477-7140

revisions:	no	date	by	description

date: 06-20-19  
 scale: 1/2"=1'-0"  
 dr. by: TARIQ  
 chk. by:

drawing no.  
**19-54F**

sheet 1 of 12

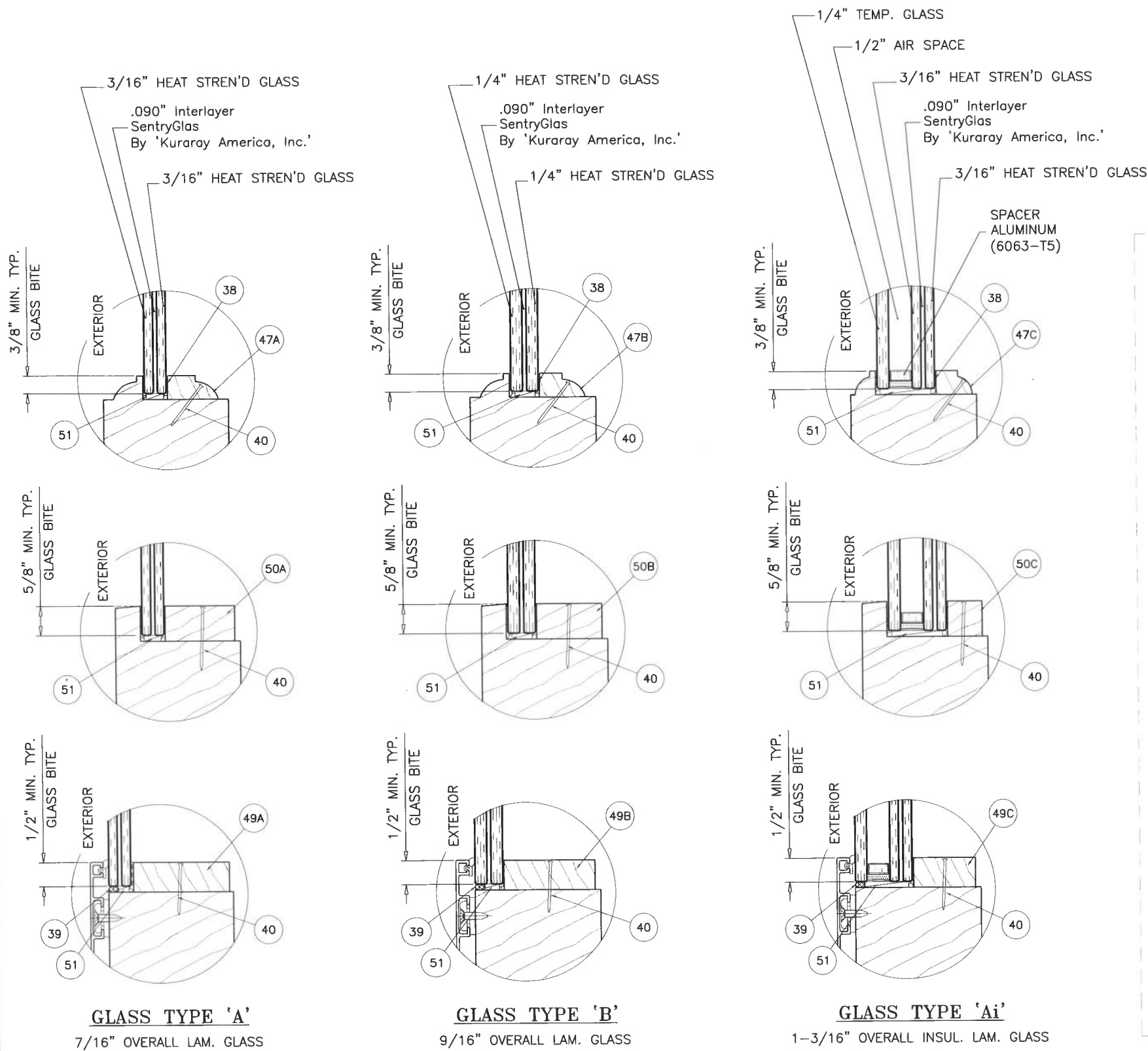

**GLASS TYPE 'A'**  
7/16" OVERALL LAM. GLASS

**GLASS TYPE 'B'**  
9/16" OVERALL LAM. GLASS

**GLASS TYPE 'Ai'**  
1-3/16" OVERALL INSUL. LAM. GLASS

**GLAZING OPTIONS**

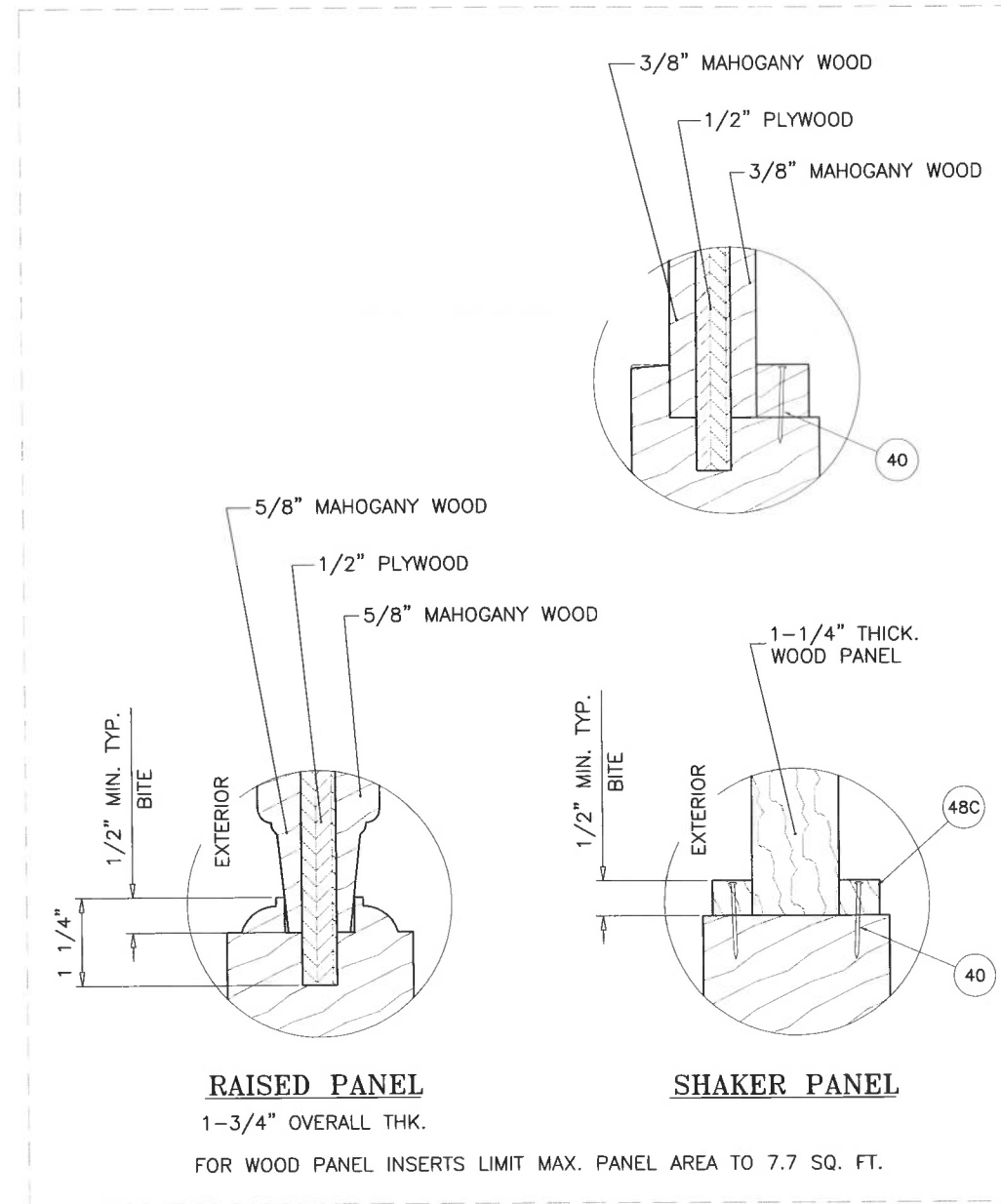

**RAISED PANEL**  
1-3/4" OVERALL THK.

**SHAKER PANEL**

FOR WOOD PANEL INSERTS LIMIT MAX. PANEL AREA TO 7.7 SQ. FT.

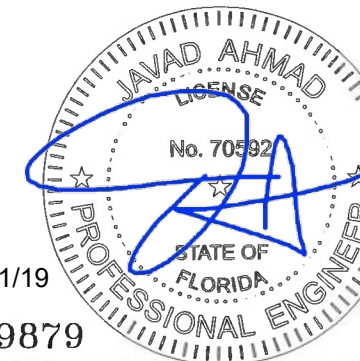

SEALED: 6/21/19

FL #29879

**afc**  
**AL-FAROOQ CORPORATION**  
ENGINEERS & PRODUCT DEVELOPMENT  
9360 SUNSET DRIVE, SUITE 220  
MIAMI, FLORIDA 33173 (C.A.N. 3538)  
TEL. (305) 264-8100 FAX. (305) 262-6978  
COMP-ANL 19-54F-EWD

INSWING GLASS WOOD PIVOT DOOR (L.M.I.)  
**Exclusive Wood Doors, Inc.**  
2000 N.W. 95Th Ave.  
Doral, FL. 33172  
Tel. (305) 477-2278 Fax. (305) 477-7140

no.	date	description

date: 06-20-19  
scale: 3/8" = 1"  
dr. by: TARIQ  
chk. by:  

drawing no.  
**19-54F**

sheet 2 of 12

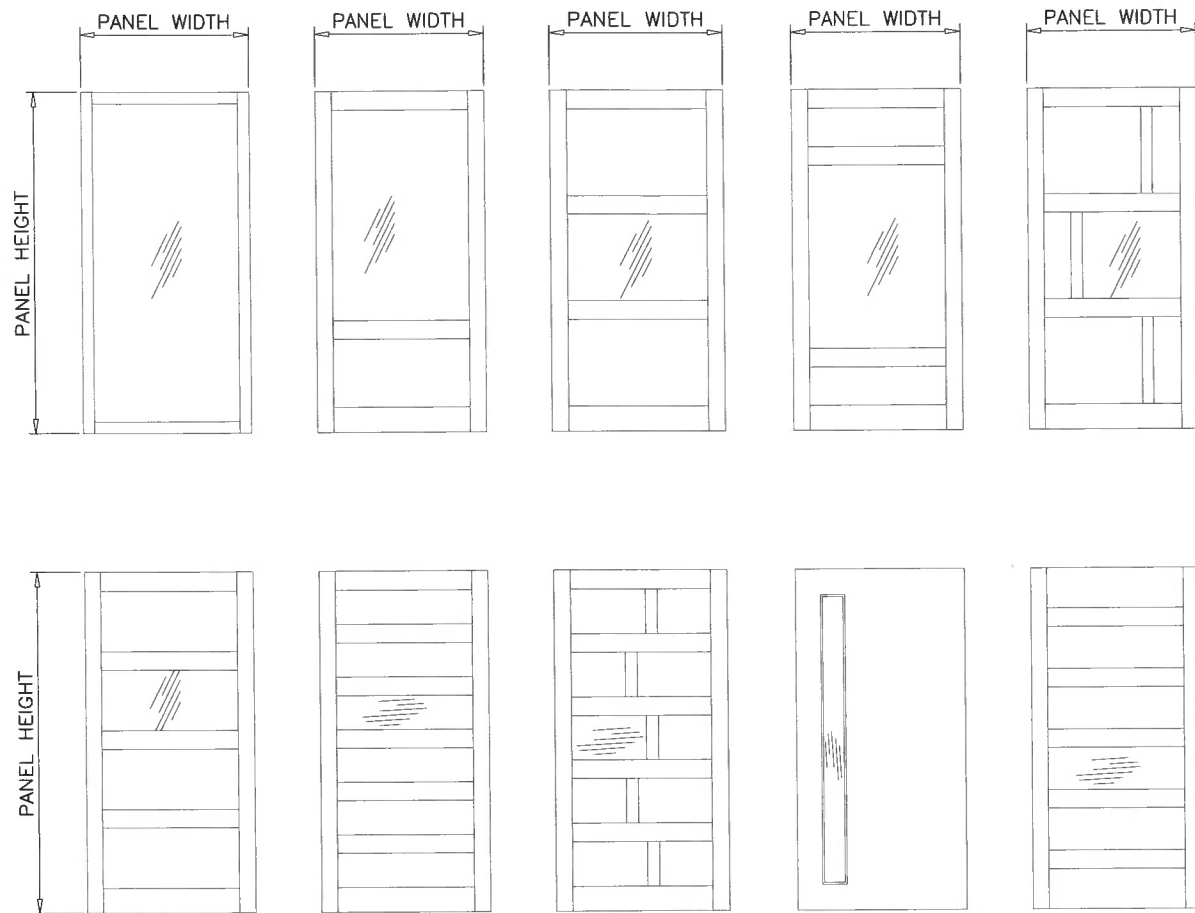

PANEL PATTERNS AS SHOWN ABOVE OR SIMILAR WITH 2.677" THICK INTERMEDIATE STILES ARE ALSO ALLOWED. FOR STILES HEIGHT AND LENGTH DIMENSION SEE BELOW.

MINIMUM DIMENSIONS:

HORIZONTAL RAILS = 2.283" HIGH TO 4" HIGH FOR LENGTHS UPTO 50-1/4"  
5" HIGH TO 20" HIGH FOR LENGTHS UPTO 61-3/8"

VERTICAL STILES = 2.283" HIGH TO 4" HIGH FOR LENGTHS UPTO 41-5/8"  
5" HIGH TO 20" HIGH FOR LENGTHS UPTO 61-3/8"

SEALED: 6/21/19

FL #29879

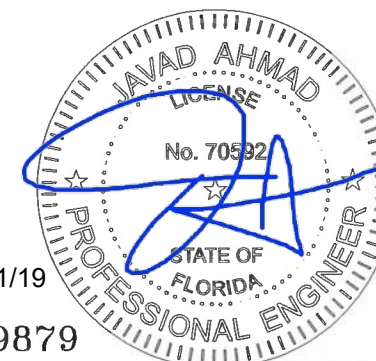

INSWING GLASS WOOD PIVOT DOOR (L.M.I.)

**Exclusive Wood Doors, Inc.**

2000 N.W. 95Th Ave.  
Doral, FL. 33172

Tel. (305) 477-2278 Fax. (305) 477-7140

revisions:	no	date	by	description

date: 06-20-19	scale: 3/8" = 1"
dr. by: TARIQ	chk. by:

drawing no.

**19-54F**

sheet 3 of 12

**af c**  
**AL-FAROOQ CORPORATION**  
ENGINEERS & PRODUCT DEVELOPMENT  
9360 SUNSET DRIVE, SUITE 220 (C.A.N. 3538)  
MIAMI, FLORIDA 33173  
TEL. (305) 264-8100 FAX. (305) 262-6978

COMP-ANL\19-54F-EWD



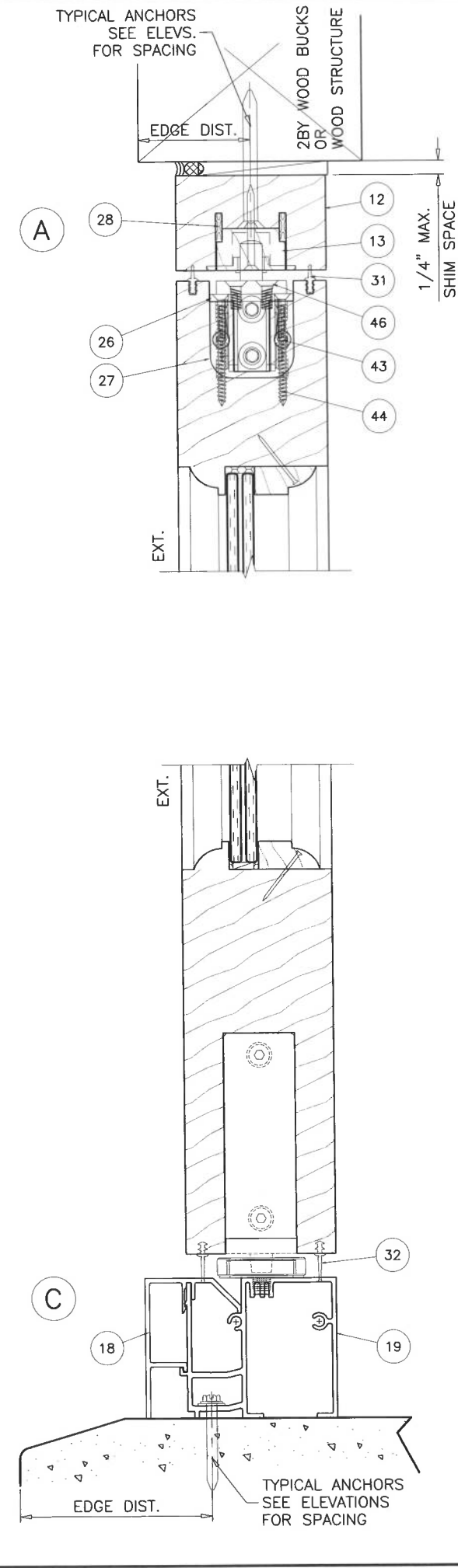
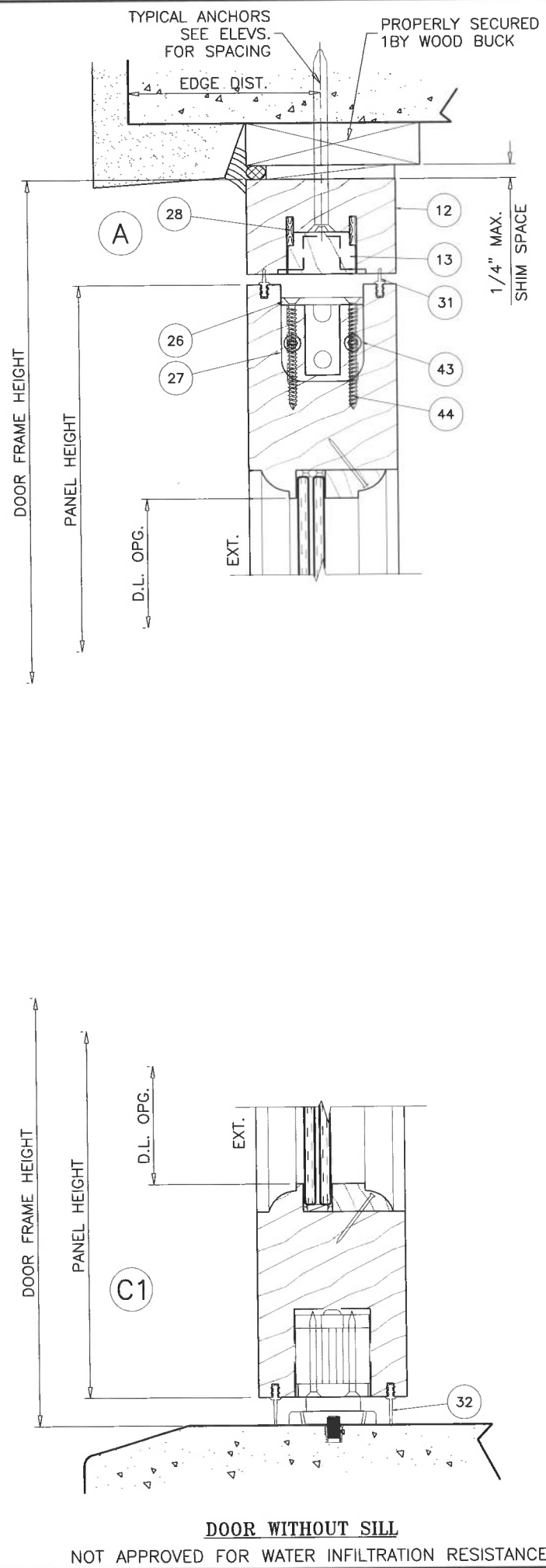
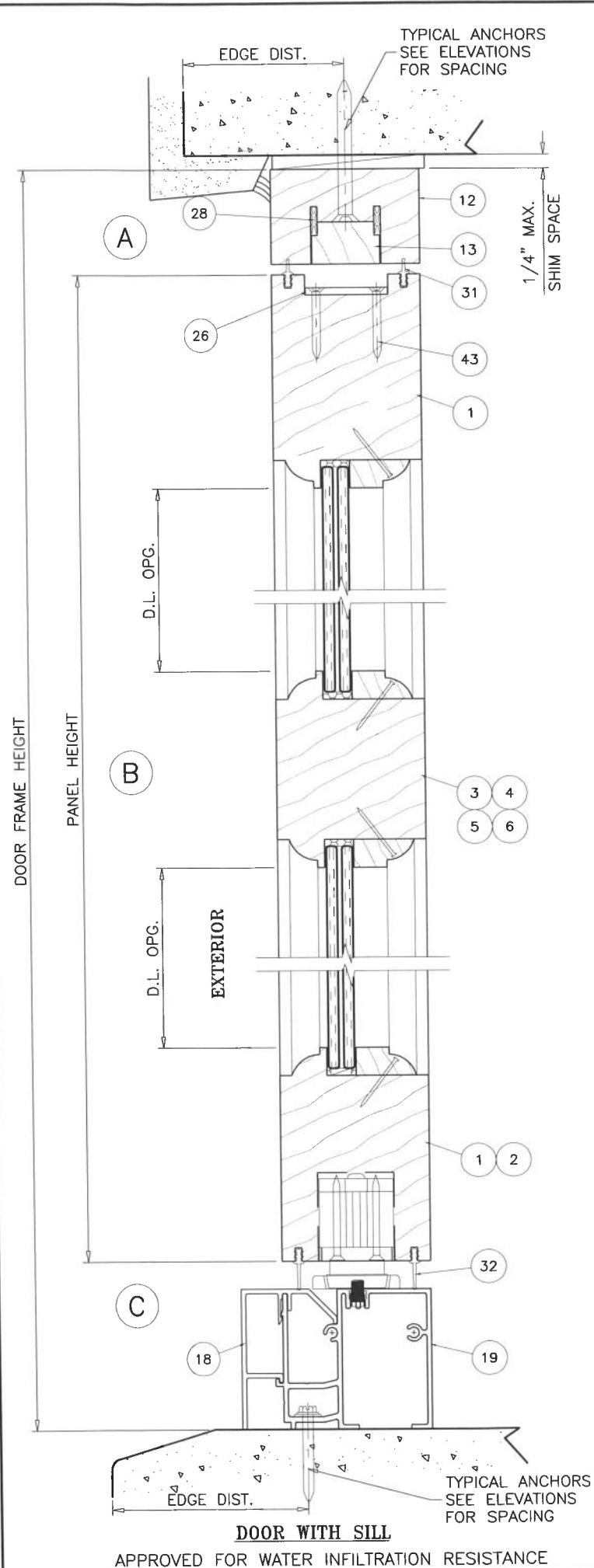

SEALED: 6/21/19  
FL #29879

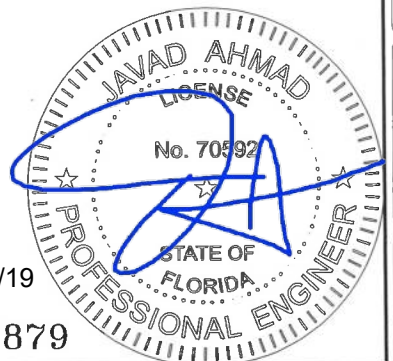

**af c**

**AL-FAROOQ CORPORATION**  
ENGINEERS & PRODUCT DEVELOPMENT  
9360 SUNSET DRIVE, SUITE 220  
MIAMI, FLORIDA 33173 (C.A.N. 3538)  
TEL. (305) 264-8100 FAX. (305) 262-6978  
COMP-ANL 19-54F-EWD

---

INSWING GLASS WOOD PIVOT DOOR (L.M.I.)  
**Exclusive Wood Doors, Inc.**  
2000 N.W. 95Th Ave.  
Doral, FL. 33172  
Tel. (305) 477-2278 Fax. (305) 477-7140

---

revisions:	no.	date	by	description

---

date: 06-20-19  
scale: 3/8" = 1"  
dr. by: TARIO  
chk. by:

---

drawing no.  
**19-54F**  
sheet 4 of 12

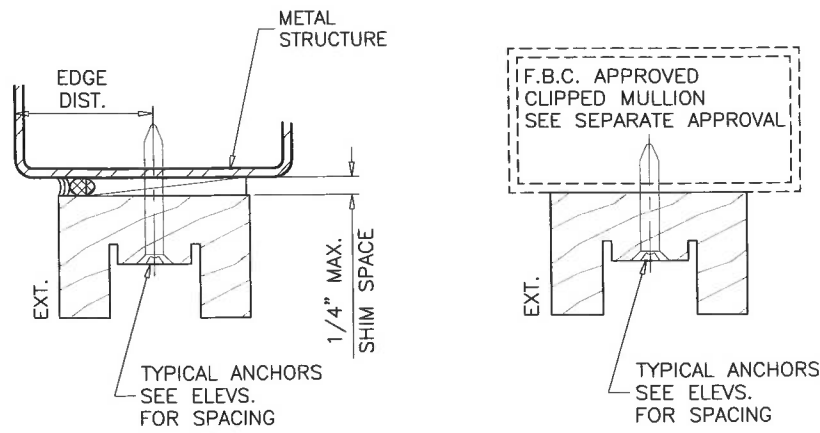

1BY OR 2BY WOOD BUCKS AND METAL STRUCTURE NOT BY EXCLUSIVE WOOD DOORS MUST SUSTAIN LOADS IMPOSED BY GLAZING SYSTEM AND TRANSFER THEM TO THE BUILDING STRUCTURE.

**TYPICAL ANCHORS:** SEE ELEV. FOR SPACING

**#14 WOOD SCREWS** (GRADE 2 CRS)  
 INTO 2BY WOOD BUCKS OR WOOD STRUCTURES  
 1-1/2" MIN. PENETRATION INTO WOOD (HEAD/JAMBS)

**1/4" DIA. TAPCON BY 'ITW'** (Fu=125 KSI, Fy=100 KSI)  
 THRU 1BY BUCKS INTO CONC. OR BLOCKS  
 1-1/2" MIN. EMBED INTO CONCRETE (HEAD/JAMBS)  
 1-1/4" MIN. EMBED INTO BLOCKS (JAMBS)

DIRECTLY INTO CONCRETE OR BLOCKS  
 1-1/2" MIN. EMBED INTO CONCRETE (HEAD/JAMBS)  
 1-1/4" MIN. EMBED INTO BLOCKS (JAMBS)

**1/4-20 TEKS OR SELF-DRILLING SCREWS** (GRADE 5 CRS)  
 INTO F.B.C. APPROVED MULLIONS  
 OR  
 INTO METAL STRUCTURES (HEAD/JAMBS)  
 (3) THREADS MIN. TO EXTEND BEYOND METAL THICKNESS  
 ALUMINUM: 1/8" THK. MIN. (6063-T5 MIN.)  
 STEEL: 1/8" THK. MIN. (Fy = 36 KSI MIN.)  
 (STEEL IN CONTACT WITH ALUMINUM TO BE PLATED OR PAINTED)

**3/16" DIA. TAPCON BY 'ITW'** (Fu=125 KSI, Fy=100 KSI)  
 DIRECTLY INTO CONCRETE  
 1-1/2" MIN. EMBED INTO CONCRETE

**CRITICAL EDGE DISTANCE**

INTO CONCRETE AND BLOCKS = 2-1/2" MIN.  
 INTO WOOD STRUCTURE = 1" MIN.  
 INTO METAL STRUCTURE = 3/4" MIN.

WOOD AT HEAD OR JAMBS SG = 0.55 MIN.  
 CONCRETE AT HEAD, SILL OR JAMBS f'c = 3000 PSI MIN.  
 C-90 HOLLOW/FILLED BLOCK AT JAMBS f'm = 2000 PSI MIN.

AT HEAD & JAMBS

AT SILL

FRAME & PANEL  
 WITHOUT CLADDING

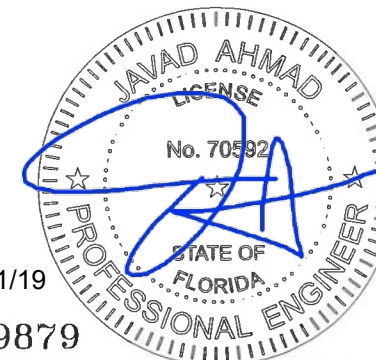

SEALED: 6/21/19

FL #29879

afc

**AL-FAROOQ CORPORATION**  
 ENGINEERS & PRODUCT DEVELOPMENT  
 9360 SUNSET DRIVE, SUITE 220 (C.A.N. 3538)  
 MIAMI, FLORIDA 33173  
 TEL (305) 264-8100 FAX (305) 262-6978

COMP-ANL\19-54F-EWD

INSWING GLASS WOOD PIVOT DOOR (L.M.I.)

**Exclusive Wood Doors, Inc.**  
 2000 N.W. 95Th Ave.  
 Doral, FL 33172  
 Tel. (305) 477-2278 Fax. (305) 477-7140

revisions:	no	date	by	description

date: 06-20-19	scale: 3/8" = 1"	dr. by: TARIQ	chk. by:
----------------	------------------	---------------	----------

drawing no.  
**19-54F**  
 sheet 5 of 12

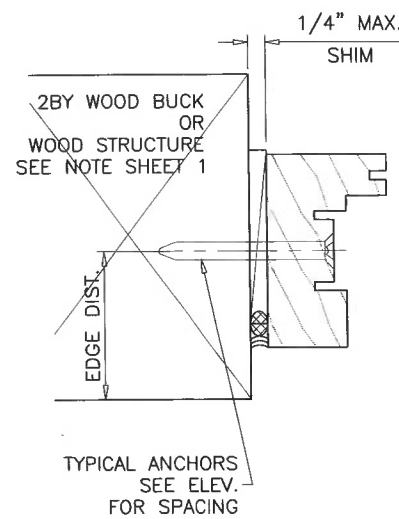
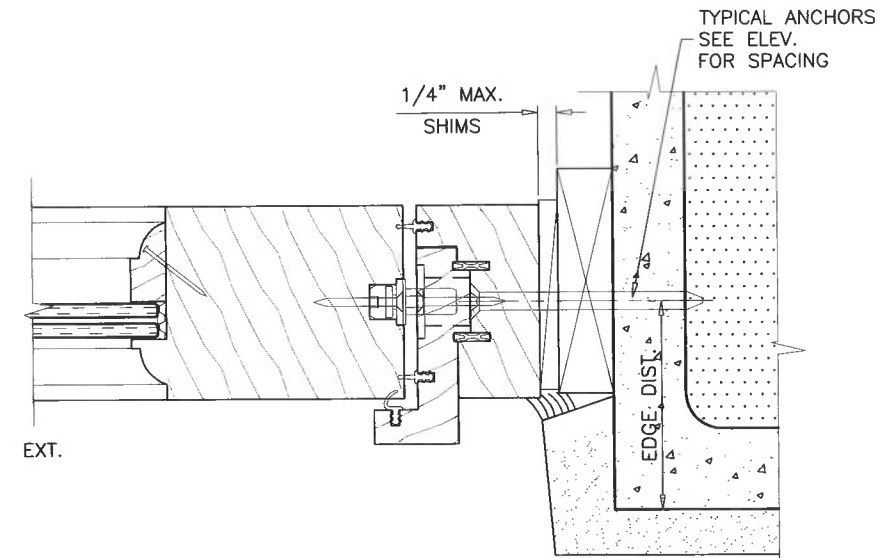
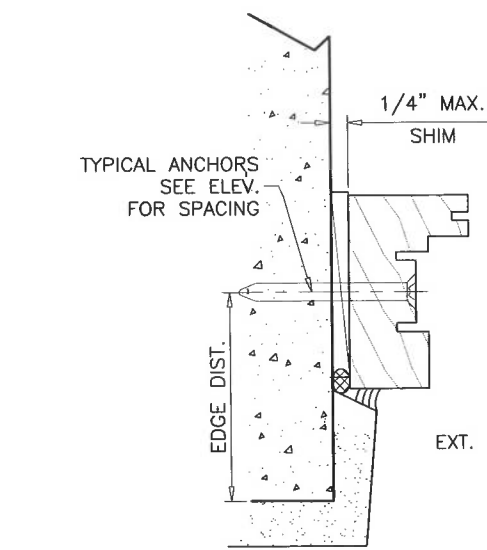
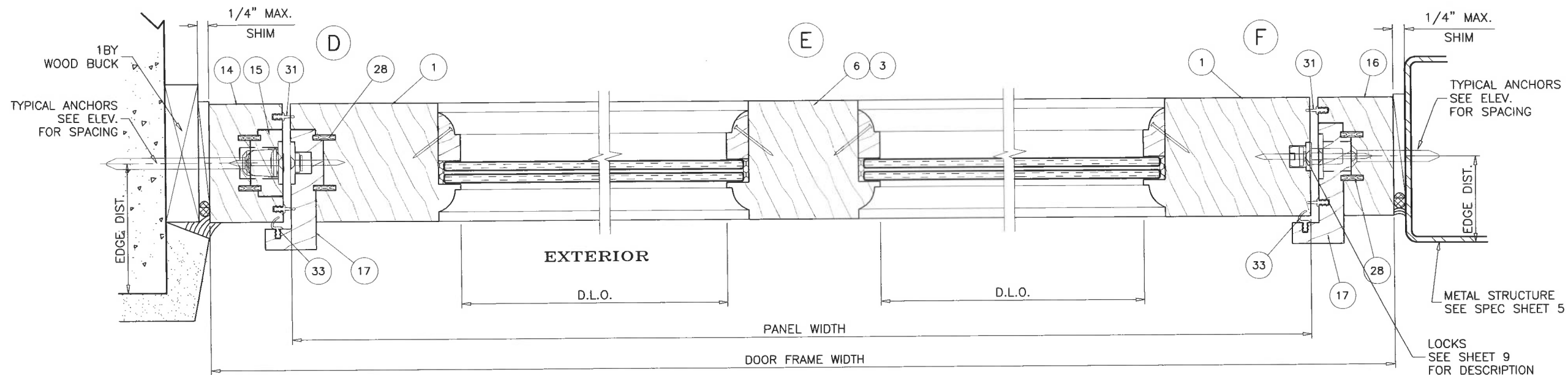

FRAME & PANEL  
WITHOUT CLADDING

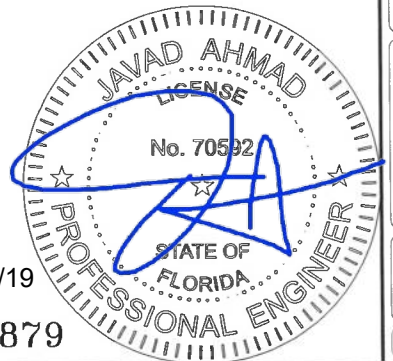

SEALED: 6/21/19  
FL #29879

**af c**  
**AL-FAROOQ CORPORATION**  
ENGINEERS & PRODUCT DEVELOPMENT  
9360 SUNSET DRIVE, SUITE 220  
MIAMI, FLORIDA 33173 (C.A.N. 3538)  
TEL. (305) 264-8100 FAX. (305) 262-6978  
COMP-ANL\19-54F-EWD

INSWING GLASS WOOD PIVOT DOOR (L.M.I.)  
**Exclusive Wood Doors, Inc.**  
2000 N.W. 95Th Ave.  
Doral, FL. 33172  
Tel. (305) 477-2278 Fax. (305) 477-7140

revisions:	
no	date by description

date: 06-20-19	scale: 3/8" = 1"	dr. by: TARIQ	chk. by:
drawing no. 19-54F			
sheet 6 of 12			



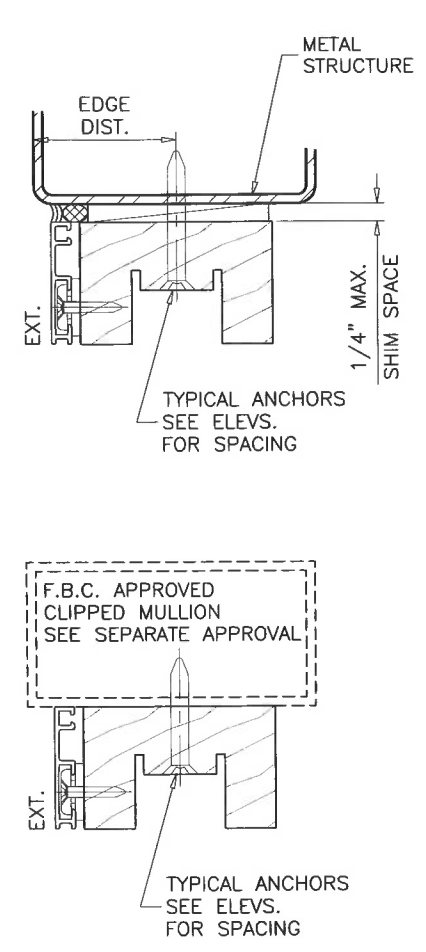
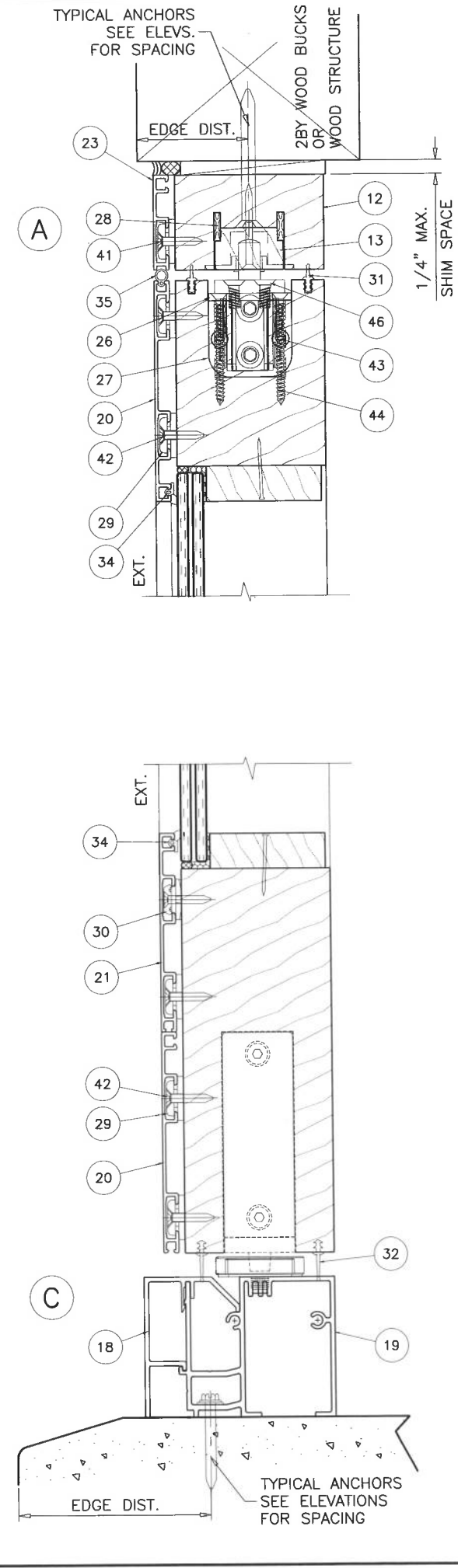
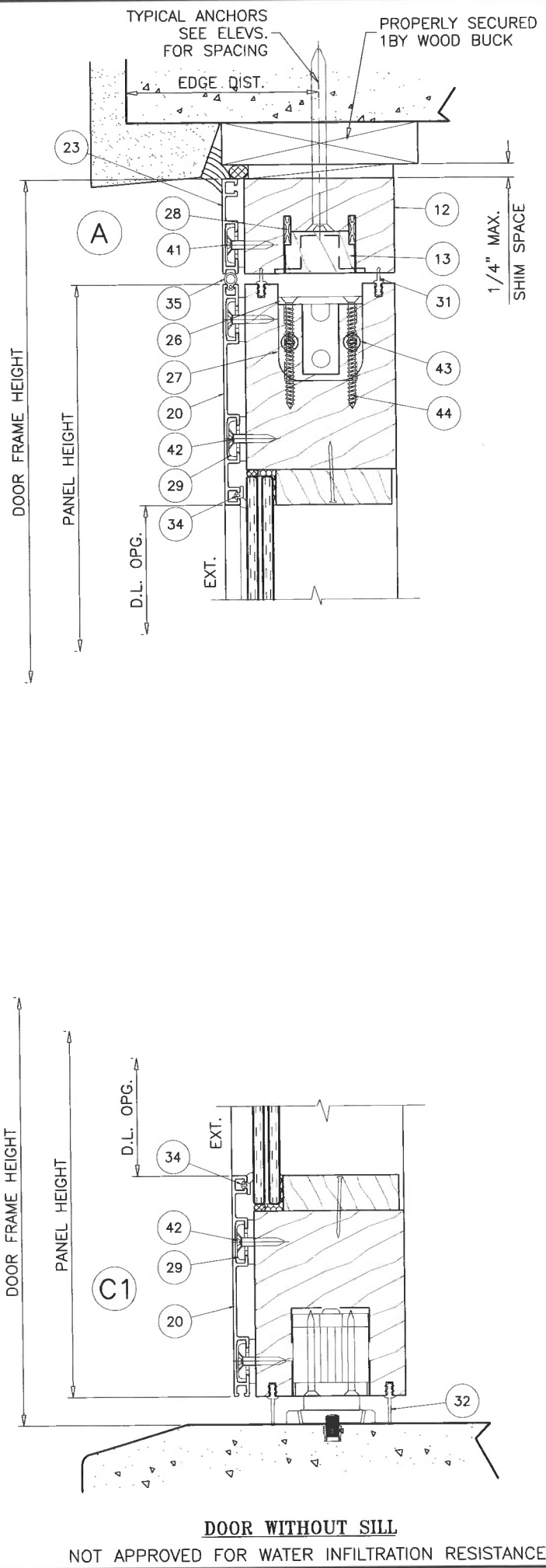
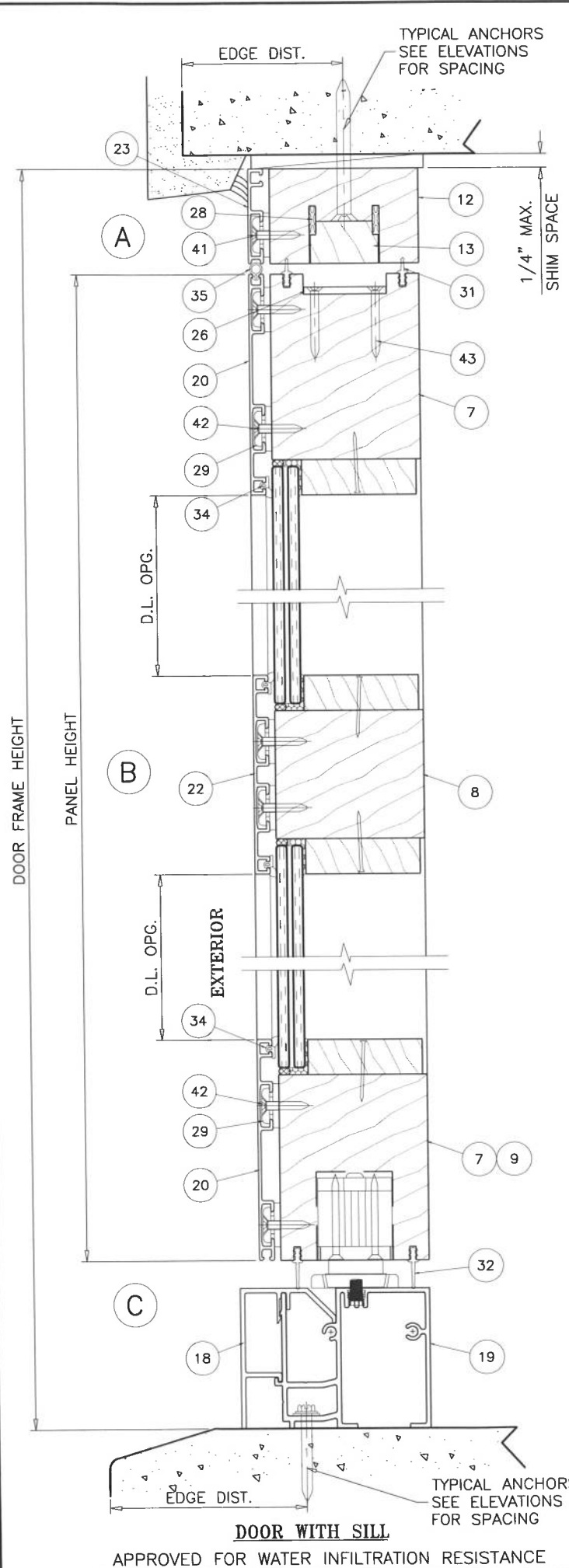

SEALED: 6/21/19

FL #29879

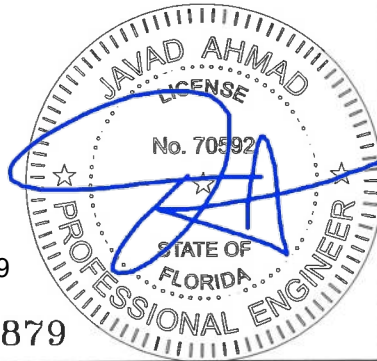

**af c**  
**AL-FAROOQ CORPORATION**  
 ENGINEERS & PRODUCT DEVELOPMENT  
 9360 SUNSET DRIVE, SUITE 220 (C.A.N. 3538)  
 MIAMI, FLORIDA 33173 TEL. (305) 262-6978 FAX. (305) 262-6978  
 COMP-ANL\19-54F-EWD

---

INSWING GLASS WOOD PIVOT DOOR (L.M.I.)  
**Exclusive Wood Doors, Inc.**  
 2000 N.W. 95Th Ave.  
 Doral, FL. 33172  
 Tel. (305) 477-2278 Fax. (305) 477-7140

---

revisions:	no	date	by	description

---

date: 06-20-19  
 scale: 3/8" = 1"  
 dr. by: TARIQ  
 chk. by:

---

drawing no.  
**19-54F**  
 sheet 7 of 12

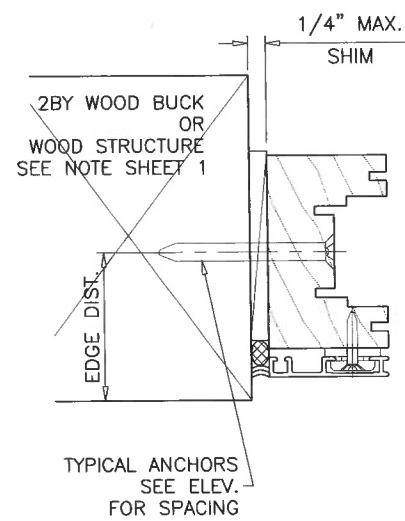
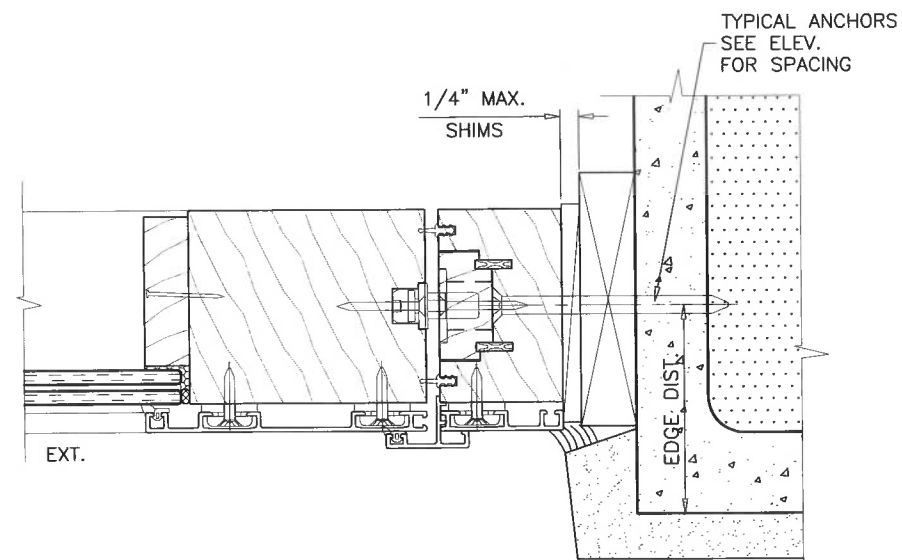
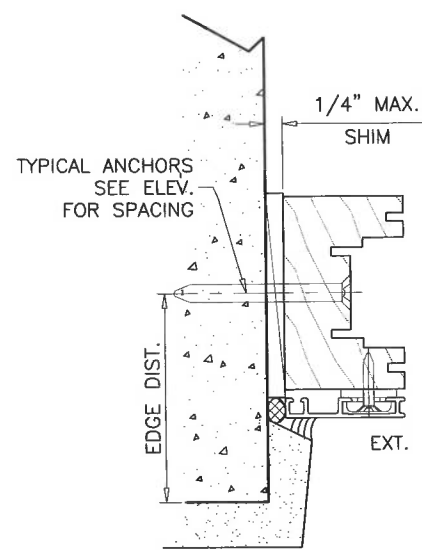
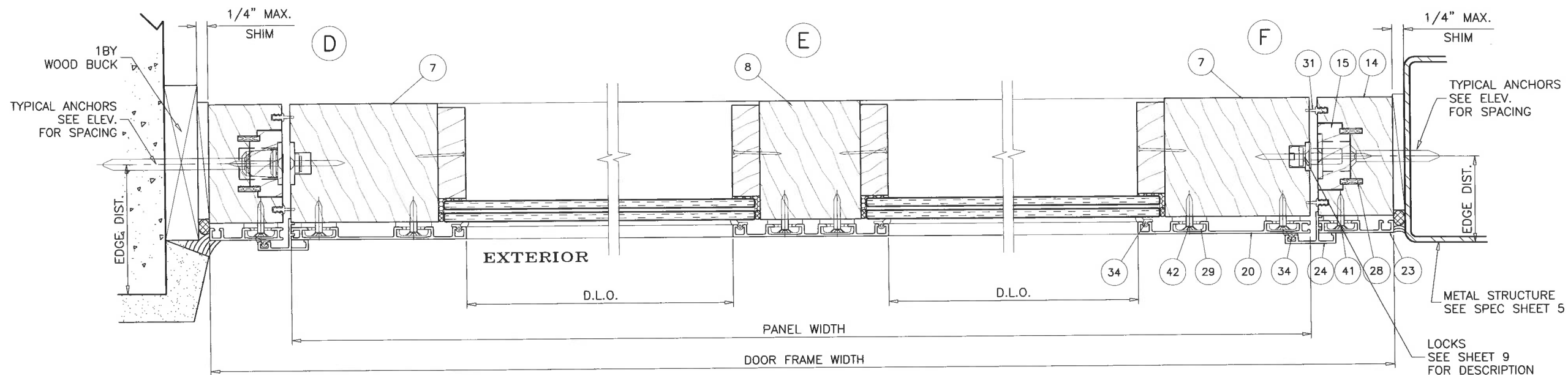

**FRAME & PANEL  
WITH ALUM CLADDING**

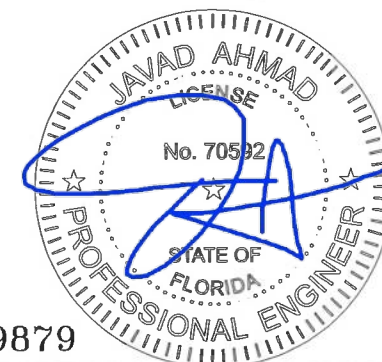

SEALED: 6/21/19

FL #29879

**af c**  
**AL-FAROOQ CORPORATION**  
 ENGINEERS & PRODUCT DEVELOPMENT  
 9360 SUNSET DRIVE, SUITE 220 (C.A.N. 3538)  
 MIAMI, FLORIDA 33173 TEL. (305) 264-8100 FAX. (305) 262-6978  
 COMP-ANL\19-54F-EWD

INSWING GLASS WOOD PIVOT DOOR (L.M.I.)

**Exclusive Wood Doors, Inc.**

2000 N.W. 95Th Ave.  
 Doral, FL. 33172  
 Tel. (305) 477-2278 Fax. (305) 477-7140

revisions:	no	date	by	description

date: 06-20-19	scale: 3/8" = 1"	dr. by: TARIQ	chk. by:
drawing no. 19-54F			
sheet 8 of 12			



ITEM #	PART #	REQD.	DESCRIPTION	MATERIAL	MANF./SUPPLIER/REMARKS
1	-	AS REQD.	STILE/RAIL	WOOD	MAHOGANY
2	-	AS REQD.	RAIL	WOOD	MAHOGANY
3	-	AS REQD.	INTERMEDIATE STILE	WOOD	MAHOGANY
4	-	AS REQD.	INTERMEDIATE STILE/RAIL	WOOD	MAHOGANY
5	-	AS REQD.	INTERMEDIATE STILE/RAIL	WOOD	MAHOGANY
6	-	AS REQD.	INTERMEDIATE STILE	WOOD	MAHOGANY
7	-	AS REQD.	STILE/RAIL	WOOD	MAHOGANY
8	-	AS REQD.	INTERMEDIATE STILE/RAIL	WOOD	MAHOGANY
9	-	AS REQD.	RAIL	WOOD	MAHOGANY
12	-	AS REQD.	FRAME	WOOD	MAHOGANY
13	-	AS REQD.	ANCHOR COVER	WOOD	MAHOGANY
14	-	AS REQD.	FRAME	WOOD	MAHOGANY
15	-	AS REQD.	ANCHOR COVER	WOOD	MAHOGANY
16	-	AS REQD.	FRAME	WOOD	MAHOGANY
17	-	AS REQD.	ASTRAGAL	WOOD	MAHOGANY
18	-	AS REQD.	SILL COVER	6063-T5	-
19	-	AS REQD.	SILL BASE	6063-T6	-
20	-	AS REQD.	STILE/RAIL CLADDING	ALUMINUM	UNIFORM
21	-	AS REQD.	STILE/RAIL CLADDING	ALUMINUM	UNIFORM
22	-	AS REQD.	INT. STILE/RAIL CLADDING	ALUMINUM	UNIFORM
23	-	AS REQD.	FRAME CLADDING	ALUMINUM	UNIFORM
24	-	AS REQD.	ASTRAGAL	ALUMINUM	UNIFORM
25	-	AS REQD.	TOP PIVOT SUPPORT PLATE	6063-T6	-
26	-	AS REQD.	RAIL SUPPORT PLATE	6063-T6	-
27	-	AS REQD.	RAIL COVER PLATE	6063-T6	-
28	-	AS REQD.	JOINT GASKET	ALUMINUM	UNIFORM
29	-	AS REQD.	CLADDING CLIP	-	UNIFORM
30	-	AS REQD.	CLADDING CLIP	-	UNIFORM
31	-	AS REQD.	WEATHERSEAL/GASKET	SILICONE	CONSERVATION TECHNOLOGIES
32	-	AS REQD.	WEATHERSEAL/GASKET	SILICONE	CONSERVATION TECHNOLOGIES
33	-	AS REQD.	WEATHERSEAL/GASKET	SILICONE	CONSERVATION TECHNOLOGIES
34	-	AS REQD.	WEATHERSEAL/GASKET	SILICONE	UNIFORM
35	-	AS REQD.	WEATHERSEAL/GASKET	SILICONE	UNIFORM
36	-	AS REQD.	DRAIN ELBOW FITTING	ABS	-
37	-	AS REQD.	DRAIN TEE FITTING	ABS	-
38	-	AS REQD.	DOWSIL 995	SILICONE	-
39	-	AS REQD.	BACKER ROD	FOAM	UNIFORM
40	-	AS REQD.	18 GA. X 1-1/4" BRAD NAIL	STEEL	AT 2" FROM ENDS AND 12" O.C.
41	-	AS REQD.	#6 X 3/4" FP SMS	ZINC PLATED	-
42	-	AS REQD.	#6 X 1" FP SMS	ZINC PLATED	-
43	-	AS REQD.	#8 X 1-1/4" FP SMS	ST. STEEL	-
44	-	AS REQD.	#8 X 2" FP SMS	ST. STEEL	-
45	-	AS REQD.	#10 X 3" FP SMS	ST. STEEL	-
46	-	AS REQD.	#12 FH MACHINE SCREWS	ST. STEEL	-
47A	-	AS REQD.	GLASS STOP (7/16" GLASS)	WOOD	MAHOGANY
47B	-	AS REQD.	GLASS STOP (9/16" GLASS)	WOOD	MAHOGANY
47C	-	AS REQD.	GLASS STOP (INSUL. LAM. GLASS)	WOOD	MAHOGANY
48A	-	AS REQD.	GLASS STOP (7/16" GLASS)	WOOD	MAHOGANY
48B	-	AS REQD.	GLASS STOP (9/16" GLASS)	WOOD	MAHOGANY
48C	-	AS REQD.	GLASS STOP (INSUL. LAM. GLASS)	WOOD	MAHOGANY
49A	-	AS REQD.	GLASS STOP (7/16" GLASS)	WOOD	MAHOGANY
49B	-	AS REQD.	GLASS STOP (9/16" GLASS)	WOOD	MAHOGANY
49C	-	AS REQD.	GLASS STOP (INSUL. LAM. GLASS)	WOOD	MAHOGANY
50A	-	AS REQD.	GLASS STOP (7/16" GLASS)	WOOD	MAHOGANY
50B	-	AS REQD.	GLASS STOP (9/16" GLASS)	WOOD	MAHOGANY
50C	-	AS REQD.	GLASS STOP (INSUL. LAM. GLASS)	WOOD	MAHOGANY
51	-	AS REQD.	SETTING BLOCKS AT 1/4 POINTS	EPDM	DUROMETER 80±5 SHORE A

**LOCKS:**

**MLS 1**

**Lock Stile / Pivot Stile:**

Hoppe HLS9000 Multipoint Lock Assembly (Tongue) With Corner Drives  
(6-8) Locking Points Engaging From Lock Stile and Pivot Stile To Frame  
Lock Handle Located at 38.5" From Bottom

**MLS 2**

**Lock Stile:**

Hoppe Contemporary 855GL Multipoint Lock Assembly (Round Bolt / Swing Hook)  
(3-4) Locking Points Engaging From Lock Stile To Frame  
Lock Handle Located at 40.16" From Bottom  
or

Hoppe HLS9000 Multipoint Lock Assembly (Tongue / Shootbolt)  
(5) Locking Points Engaging From Lock Stile To Frame  
Lock Handle Located at 36" From Bottom

**Pivot Stile:**

Hoppe High Performance Lock (HPL) Assembly (Tongue)  
(2-3) Locking Points Engaging From Pivot Stile To Frame  
Lock Handle Located to at 36" or 40.16" From Bottom

**PIVOT HINGES:**

'SYSTEM ONE' OR 'SYSTEM M' PIVOT HINGES BY 'FRITSJURGENS'

**SEALANTS:**

ALL JOINTS AND FRAME CONNECTIONS SEALED WITH  
WHITE/ALUMINUM COLORED SILICONE.

**TYPICAL WOOD MAHOGANY LUMBER**

SPECIFIC GRAVITY = 0.44 MIN.  
GRADE = 2 MIN.  
MOISTURE CONTENT = 19% MAX.

SEALED: 6/21/19

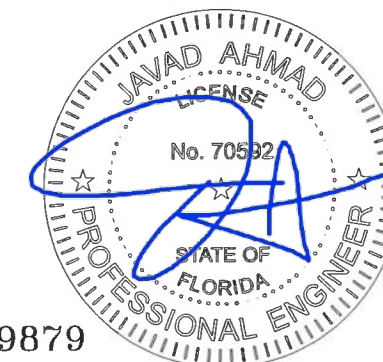

FL #29879

**af c**  
**AL-FAROOQ CORPORATION**  
ENGINEERS & PRODUCT DEVELOPMENT  
9360 SUNSET DRIVE, SUITE 220 (C.A.N. 3538)  
MIAMI, FLORIDA 33173  
TEL. (305) 264-8100 FAX. (305) 262-6978  
COMP - ANL \ 19 - 54F - EWD

INSWING GLASS WOOD PIVOT DOOR (L.M.I.)

**Exclusive Wood Doors, Inc.**  
2000 N.W. 95Th Ave.  
Doral, FL. 33172  
Tel. (305) 477-2278 Fax. (305) 477-7140

revisions:	no	date	by	description

date: 06-20-19  
scale: 3/8" = 1"  
dr. by: TARIQ  
chk. by:  
drawing no.  
**19-54F**  
sheet 9 of 12

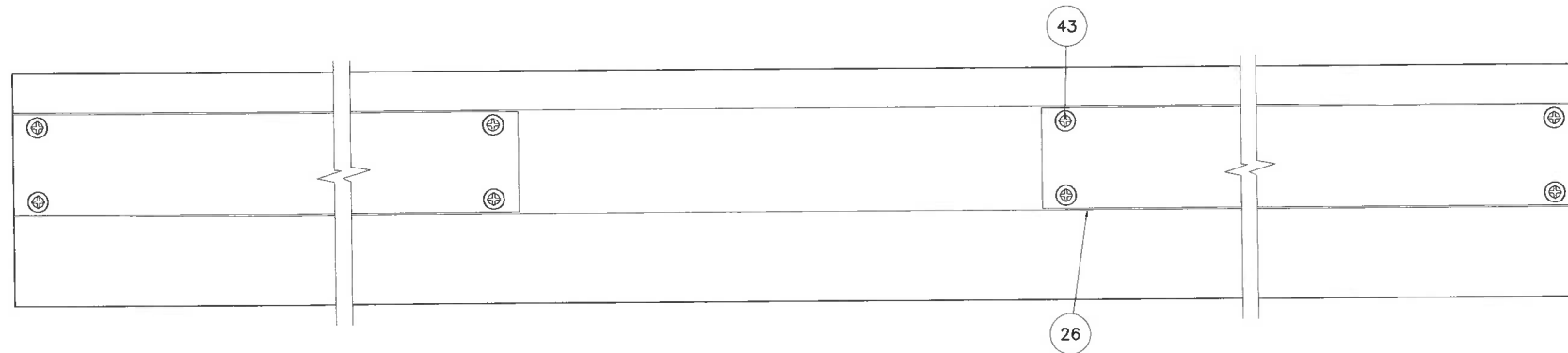
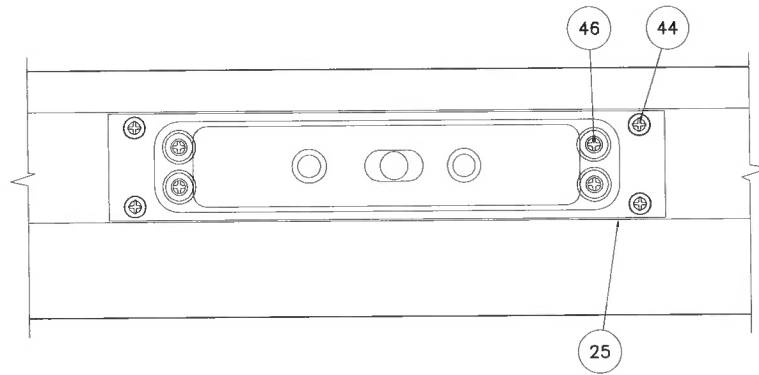
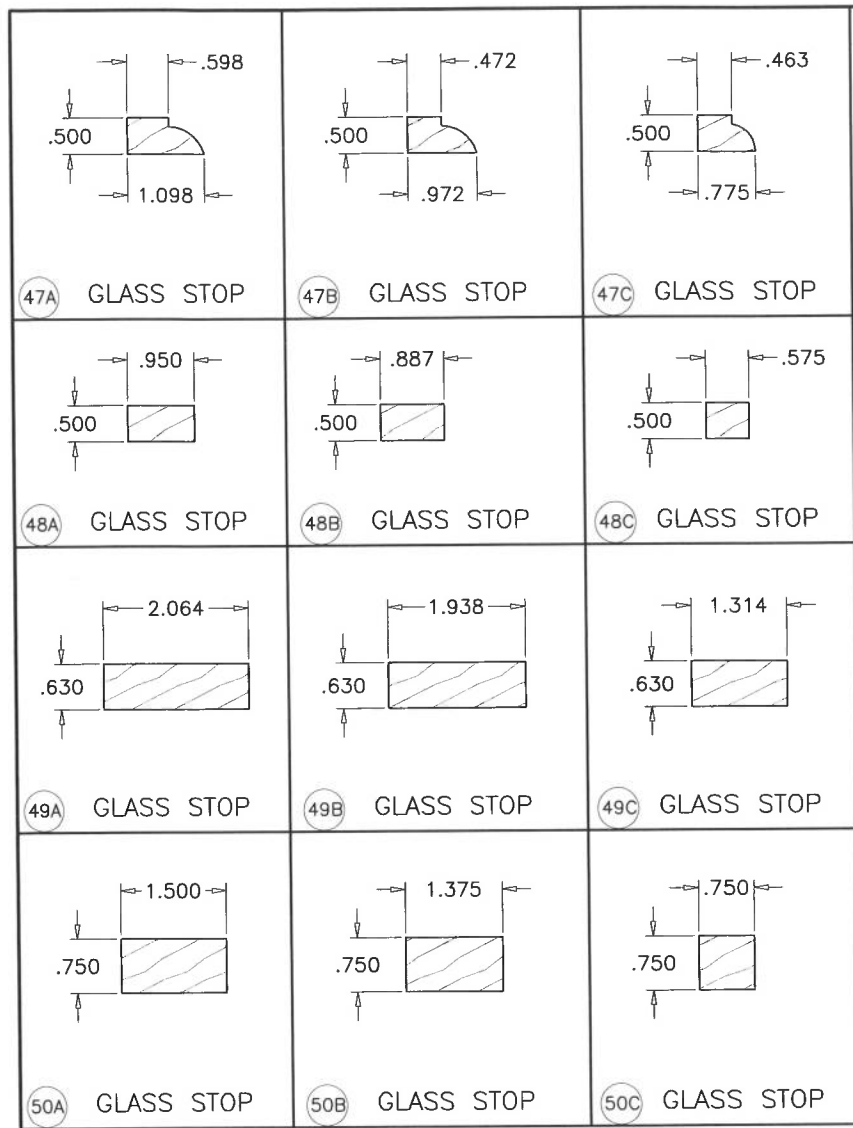

SEALED: 6/21/19

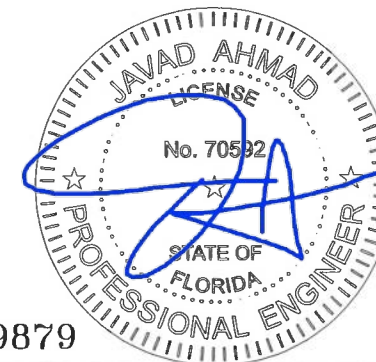

FL #29879

**af c**  
**AL-FAROOQ CORPORATION**  
 ENGINEERS & PRODUCT DEVELOPMENT  
 9360 SUNSET DRIVE, SUITE 220 (C.A.#. 3538)  
 MIAMI, FLORIDA 33173 TEL. (305) 264-8100 FAX. (305) 262-6978  
 COMP-ANL\19-54F-EWD

INSWING GLASS WOOD PIVOT DOOR (L.M.I.)  
**Exclusive Wood Doors, Inc.**  
 2000 N.W. 95Th Ave.  
 Doral, FL. 33172 Tel. (305) 477-2278 Fax. (305) 477-7140

revisions:	no	date	by	description
date:	06-20-19			
scale:	3/8" = 1"			
dr. by:	TARIQ			
chk. by:				
drawing no.	19-54F			
sheet	10 of 12			

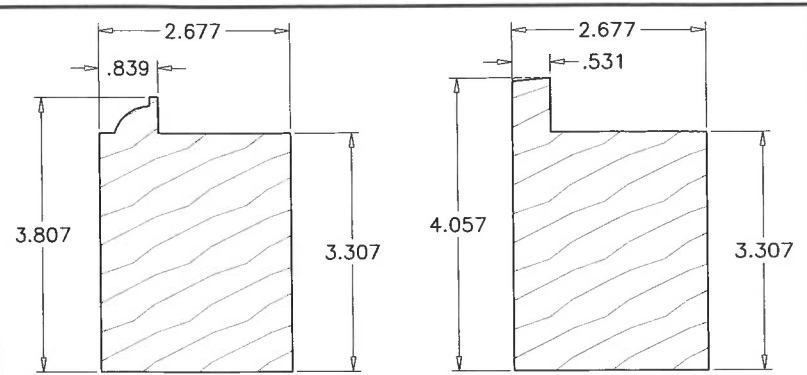

1 STILE/RAIL

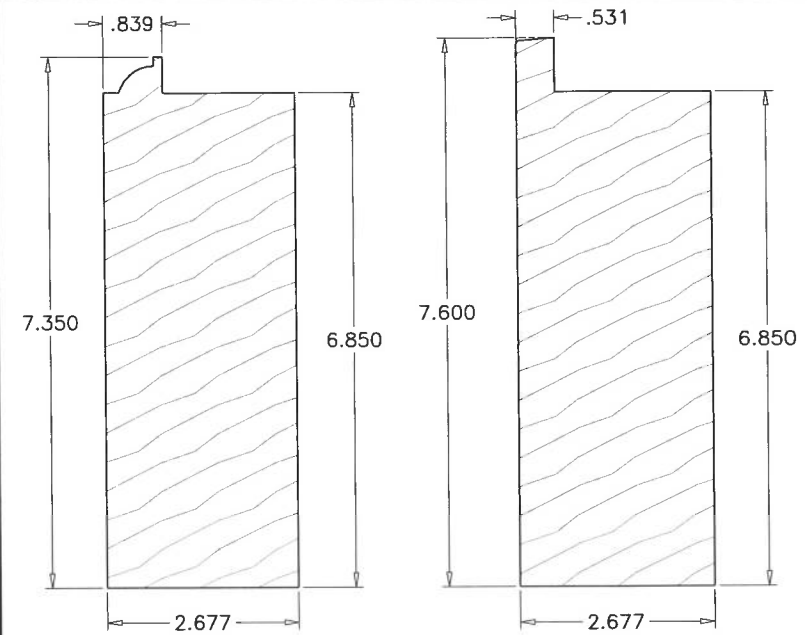

2 RAIL

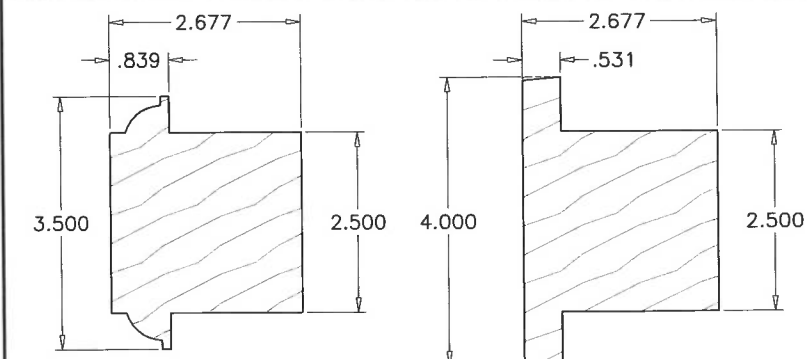

3 INTERMEDIATE STILE

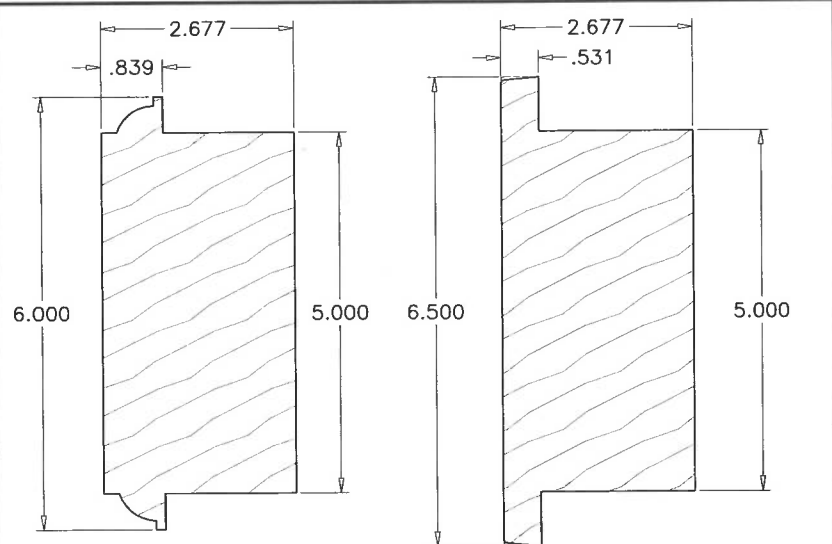

4 INTERMEDIATE STILE/RAIL

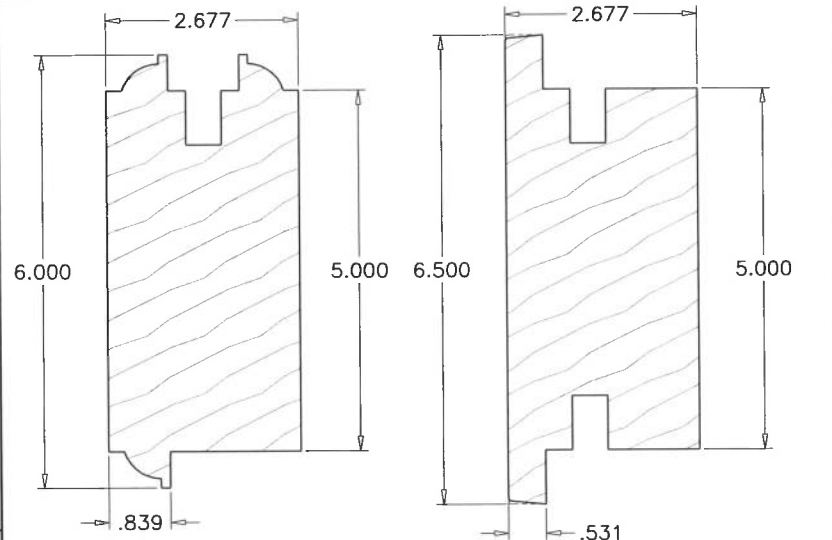

5 INTERMEDIATE STILE/RAIL

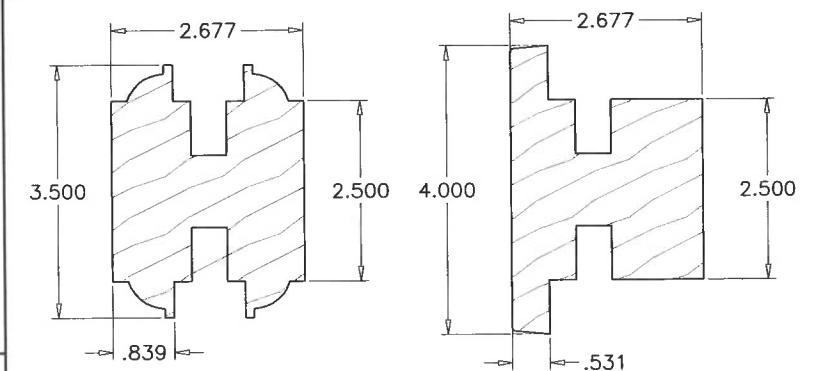

6 INTERMEDIATE STILE

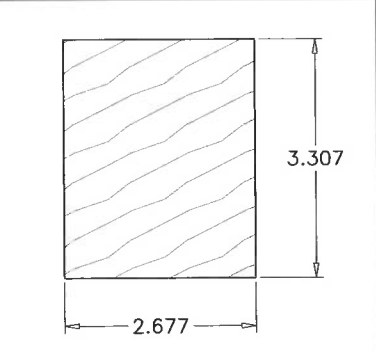

7 STILE/RAIL

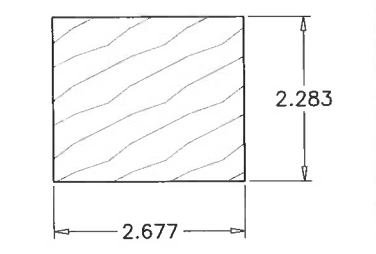

8 INTERMEDIATE STILE/RAIL

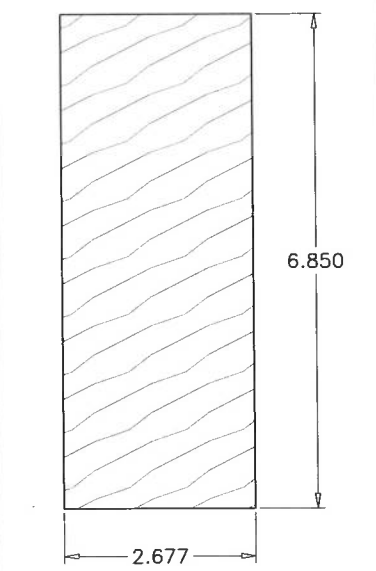

9 INTERMEDIATE STILE/RAIL

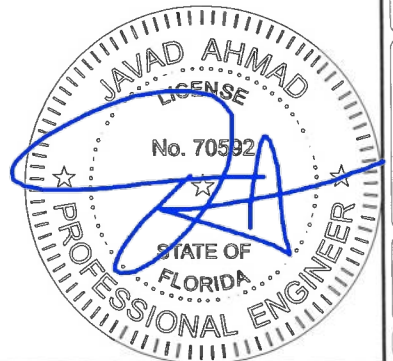

SEALED: 6/21/19  
FL #29879

**afc**  
**AL-FAROOQ CORPORATION**  
ENGINEERS & PRODUCT DEVELOPMENT  
9360 SUNSET DRIVE, SUITE 220  
MIAMI, FLORIDA 33173 (C.A.N. 3538)  
TEL. (305) 264-8100 FAX. (305) 262-6978  
COMP-ANL\19-54F-EWD

INSWING GLASS WOOD PIVOT DOOR (L.M.I.)  
**Exclusive Wood Doors, Inc.**  
2000 N.W. 95Th Ave.  
Doral, FL. 33172  
Tel. (305) 477-2278 Fax. (305) 477-7140

revisions:	no	date	by	description

date: 06-20-19  
scale: 3/8" = 1"  
dr. by: TARIQ  
chk. by:

drawing no.  
**19-54F**  
sheet 11 of 12



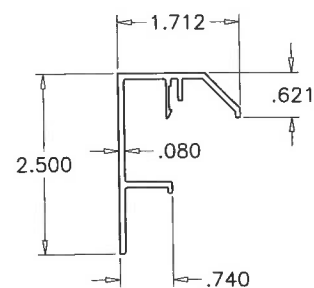

18 SILL COVER

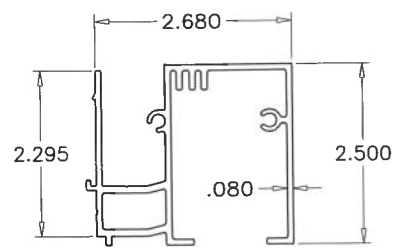

19 SILL BASE

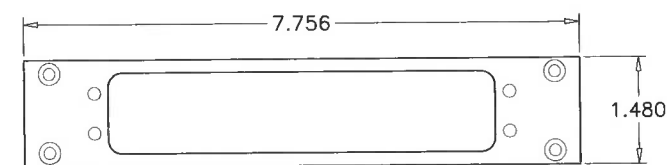

25 TOP PIVOT SUPPORT PLATE

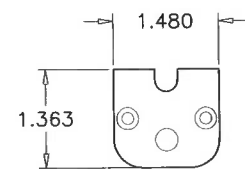

27 RAIL COVER PLATE

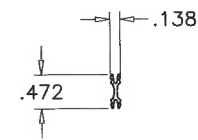

28 JOINT GASKET

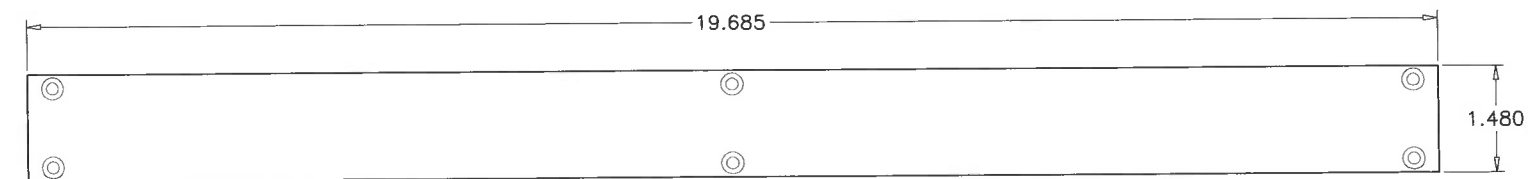

26 RAIL SUPPORT PLATE

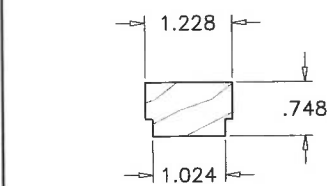

13 ANCHOR COVER

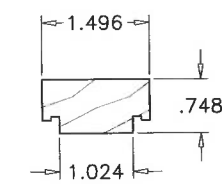

15 ANCHOR COVER

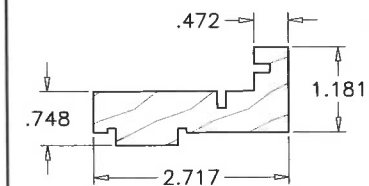

17 ASTRAGAL

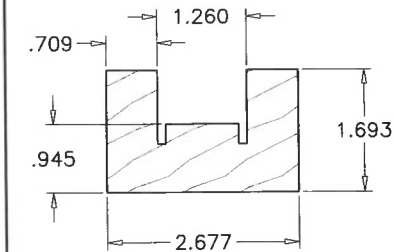

12 FRAME

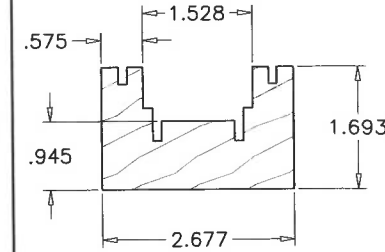

14 FRAME

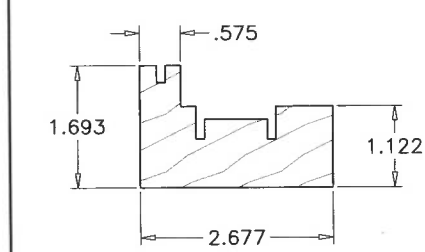

14 FRAME

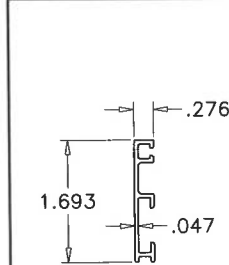

23 FRAME CLADDING

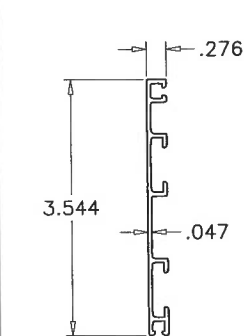

21 STILE/RAIL CLADDING

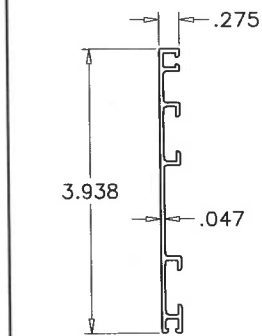

20 STILE/RAIL CLADDING

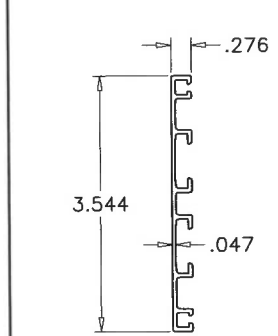

22 INT. STILE/RAIL CLADDING

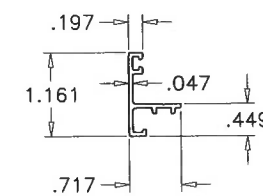

24 ASTRAGAL

SEALED: 6/21/19  
FL #29879

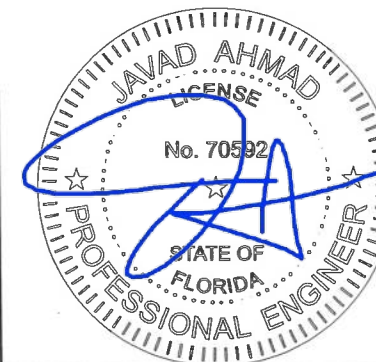

**af c**  
**AL-FAROOQ CORPORATION**  
ENGINEERS & PRODUCT DEVELOPMENT  
9360 SUNSET DRIVE, SUITE 220 (C.A.N. 3538)  
MIAMI, FLORIDA 33173 TEL. (305) 264-8100 FAX. (305) 262-6978  
COMP-ANL\19-54F-EWD

INSWING GLASS WOOD PIVOT DOOR (L.M.I.)  
**Exclusive Wood Doors, Inc.**  
2000 N.W. 95Th Ave.  
Doral, FL. 33172  
Tel. (305) 477-2278 Fax. (305) 477-7140

revisions:	no.	date	by	description

date: 06-20-19  
scale: 3/8" = 1"  
dr. by: TARIQ  
chk. by:

drawing no.  
**19-54F**

sheet 11.1 of 12

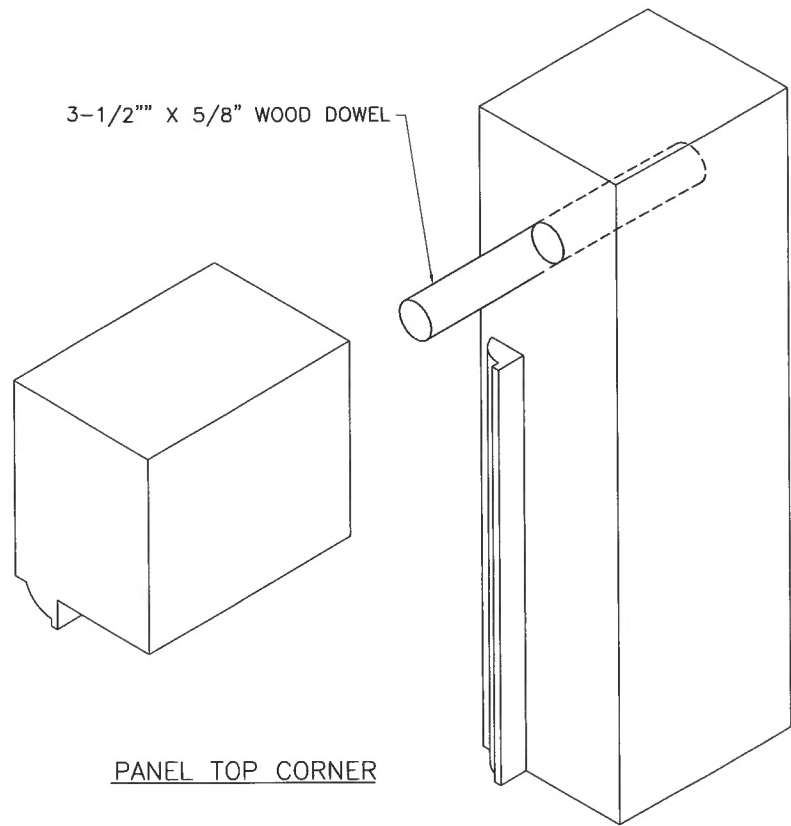

PANEL TOP CORNER

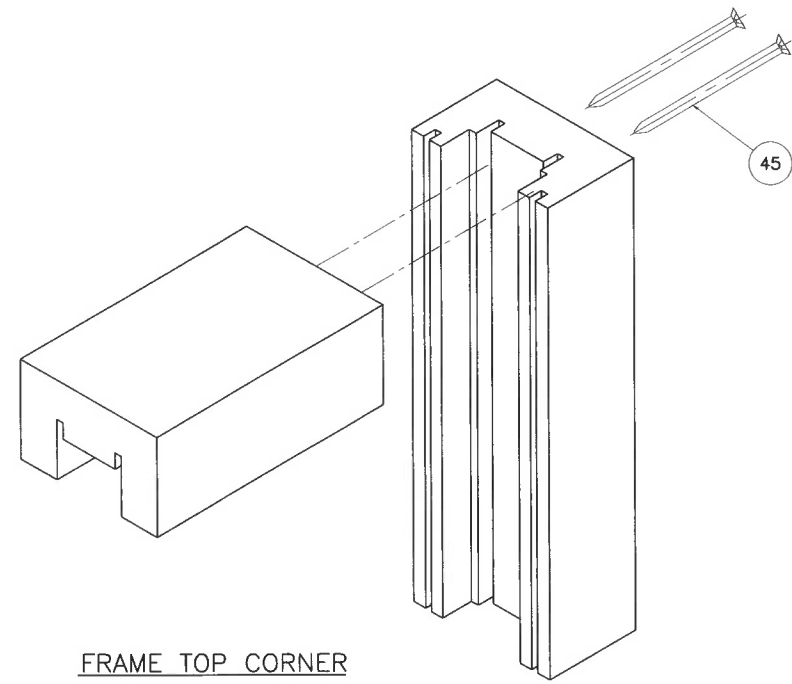

FRAME TOP CORNER

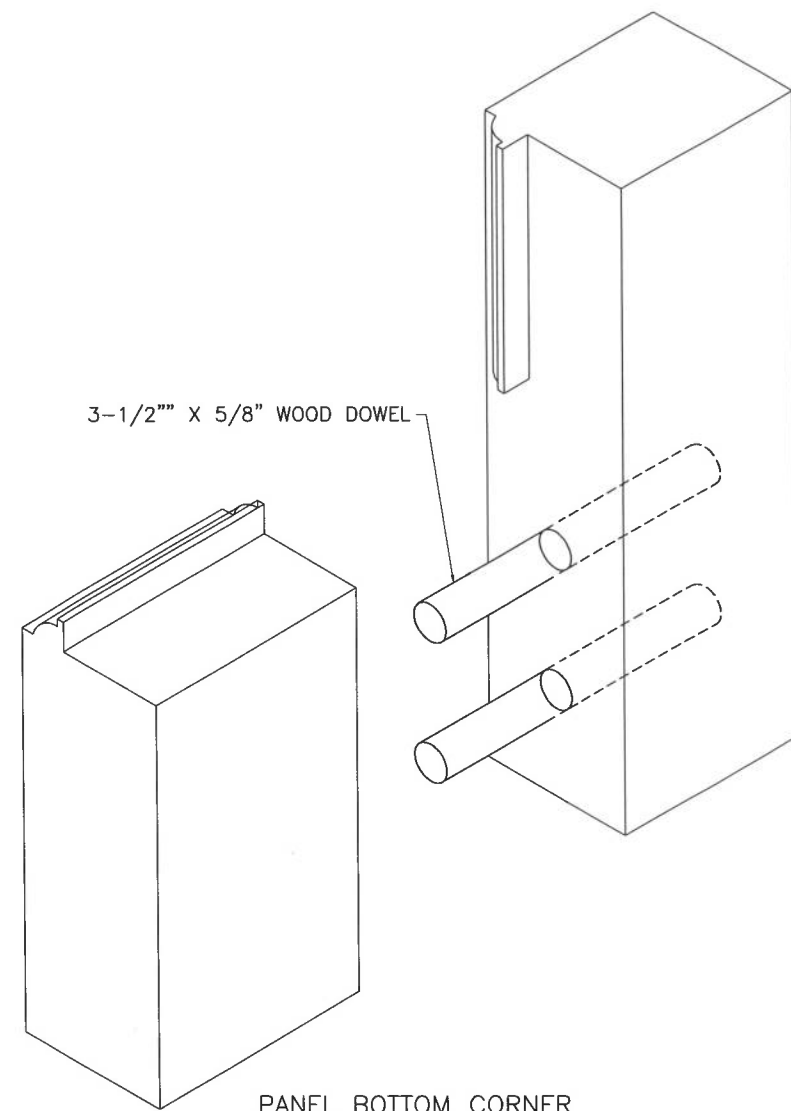

PANEL BOTTOM CORNER

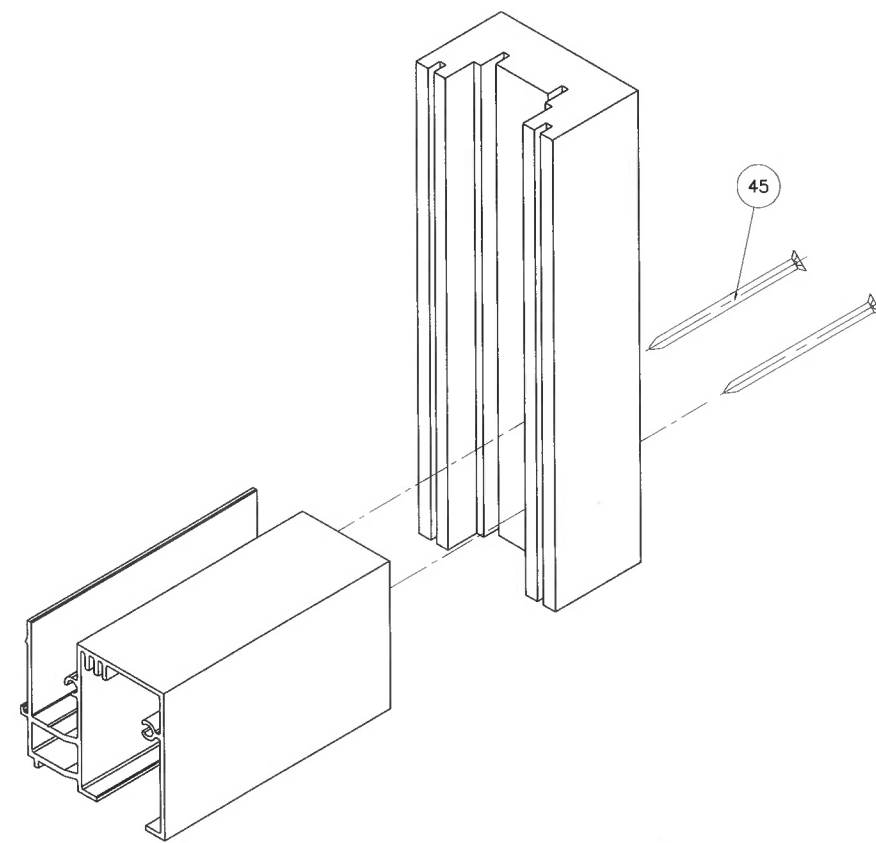

FRAME BOTTOM CORNER

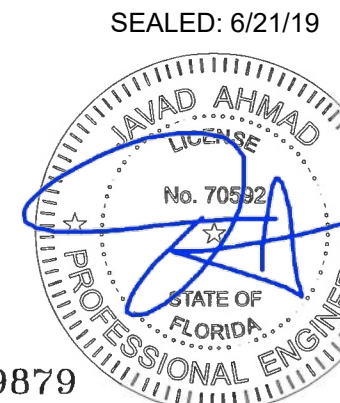

SEALED: 6/21/19

FL #29879

**afc**

**AL-FAROQ CORPORATION**  
 ENGINEERS & PRODUCT DEVELOPMENT  
 9360 SUNSET DRIVE, SUITE 220  
 MIAMI, FLORIDA 33173 (C.A.N. 3538)  
 TEL. (305) 264-8100 FAX. (305) 262-6978

COMP-ANL\19-54F-EWD

INSWING GLASS WOOD PIVOT DOOR (L.M.I.)

**Exclusive Wood Doors, Inc.**

2000 N.W. 95Th Ave.  
 Doral, FL. 33172  
 Tel. (305) 477-2278 Fax. (305) 477-7140

revisions:  
 no. date by description

date: 06-20-19  
 scale: 3/8" = 1"

dr. by: TARIQ  
 chk. by:

drawing no.  
**19-54F**

sheet 12 of 12